

## Warewashing Dual rinse rack type dishwasher, 150 racks/hour, electric, 50Hz

ITEM # \_\_\_\_\_

MODEL # \_\_\_\_\_

NAME # \_\_\_\_\_

SIS # \_\_\_\_\_

AIA # \_\_\_\_\_

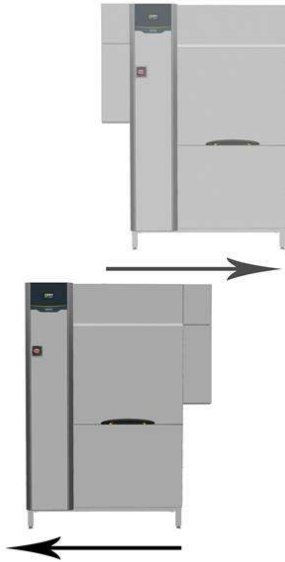
**536035 (ZDR150EC5)**

Dual rinse rack type dishwasher, 150 racks/hour, advanced filtering system, electric, touch screen, customized direction on-site, 50Hz

### Short Form Specification

**Item No.** \_\_\_\_\_

Unit to be dual rinse rack type dishwasher. Dual rinse with built-in stabilized pressure valve ensures the right rinsing pressure for optimum hygiene results. Maximum Water Contact (MWC) wash arms are positioned along the full length of the wash tank. Powerful wash pump and specially designed wash spray arms guarantee cleaning. Washing is done with water circulating at 55-65°C. Final rinsing is done with clean water heated up to 85°C. Dual rinse technology provides rinse water covering maximum the rinse area to ensure hygiene on washed wares. Low rinse water consumption of 1.2liters per rack at maximum speed of 150racks/hour. Three conveyor speeds are selectable by the operator with maximum capacity of 150racks/hour. Intuitive touch screen control panel provides easy communication on different levels. Large counter-balance door has heat and noise insulation with easy internal access. Advanced filtering system removes majority of soil from the wash water to ensure clean water for long time. Built-in drain valve in the tank allows automatic dump and fill to refresh the water in the tank without interruption. Standard end of the day self cleaning cycle and sanitation cycle. Operating direction of the machine is decided by customer on-site depending on the layout flow with pre-arranged right to left from the factory.

**APPROVAL:** \_\_\_\_\_

### Main Features

- Automatic drain, clean and sanitize cycles featured as standard. The internal chamber, is completely cleaned or sanitized avoiding bacteria proliferation for maximum hygiene and reducing manual work/time for operator.
- Dual rinse technology ensures maximum rinse water covering every corner of the rack inside the rinse area for perfect hygiene on washed wares.
- Three conveyor speeds can be selected through the control panel by the operator and customized on-site.
- Large counter balanced inspection door allow unrestricted all-round access to the wash and rinse area. Door is insulated with injected foam. This adds strength as well as reduces noise and heat loss.
- Unit equipped with USB port making it simple to read data such as machine identification, counters and consumption, components, devices and alarm logs. Machine parameters can be uploaded and downloaded and firmware updated.
- Adjustable feet for full access underneath the machine for cleaning.
- All internal components: wash and rinse arms, tank filters, curtains can be easily removed for cleaning.
- Intuitive touch screen control panel features user-friendly display to easily operate the machine and to monitor machine status. Three different levels of interaction are available each show relevant messages and information to the operator, the general maintenance staff and the authorized service partners.
- Built-in drain valve in the tanks allows automatic dump and fill to refresh the water in the tank without any interruption of the washing process.
- IP25 protection against water jets, solid objects and small animals (larger than 6 mm).
- Maximum capacity per hour of 150 racks easy to switch to DIN 10510 compliant or other speed.
- Advanced Filtering System provides cleaner wash water and higher active detergent thus ensuring better washing performances and lower running costs.

### Construction

- Deep drawn pressed wash tank with fully rounded corners, sloped towards the drain to prevent dirt buildup, provides fast drainage in just a few minutes. With no welding points the pressed tank offers a guaranteed water tight solution.
- Modularity design allows the machine not only be disassembled for delivery and re-assembled at customer's site, but also to be customized and upgraded on-site and over time.
- Dishwasher structure is held together with a solid 50 x 50 mm stainless steel frame to provide long-term sturdiness.
- All electric components are put in one IP65 central box isolated from water and steam to ensure high reliability.
- External pre-arrangement for inlet water, drain water, detergent & rinse aid connections for fast and easy installation on both sides of the unit.
- All main components made in heavy duty anti-

corrosive 304 type stainless steel: external front, side panels and internal chambers, wash and rinse arms, doors and rack transportation system.

- The feeding direction is right to left as pre-arrangement from the factory, but it can be simply reversed on-site to left to right.
- The unit is built on modularity concept for easy to add pre-wash and dryer modules on-site.

### Sustainability

- Auto-start/stop equipped in different zones ensures that the zone runs only when a rack is passing through it. This reduces water, energy, chemical consumption and noise.
- All chambers without internal pipes and therefore no hidden dirt traps.
- Built-in stabilized pressure valve ensures constant pressure throughout the rinsing cycle regardless of inlet water pressure.
- Self-draining vertical wash pumps provide maximum hygiene.
- Automatic back-up mode is activated when a failure occurs. Guided troubleshooting for fast fixes including 150 precise notifications and 23 easy-to-follow processes.
- Dual rinse with stabilized pressure valve guarantees rinse water consumption of 1.2 liters/ rack regardless of inlet water pressure to ensure low energy, water, detergent and rinse aid consumption.

- Splash hood kit for single and dual rinse Rack Type dishwasher, 200 mm PNC 865498
- Silicon curtains for single and dual rinse Rack Type dishwasher PNC 865503
- Kit electronic board for Dual Rinse Rack Type Dishwasher PNC 865506
- Kit delime & door cleaning for dual for Rinse Rack Rack Type Dishwasher PNC 865507
- Kit electronic connection for motorized table and remote pre wash module for Dual Rinse Rack Type Dishwasher PNC 865508
- Set of 6 baskets: 2 for trays, 2 for plates, 1 for cutlery and 1 for cups PNC 867050
- Set of 9 baskets: 2 for trays, 3 for plates, 2 for cutlery and 2 for cups PNC 867051
- Ethernet board (NIU-LAN) for rack type dishwashers PNC 922696

### Included Accessories

- 1 of Splash hood kit for single and dual PNC 865498  
rinse Rack Type dishwasher, 200 mm

### Optional Accessories

- Medium pre-wash zone for Dual Rinse Rack Type Dishwasher PNC 535095
- Large pre-wash zone for Dual Rinse Rack Type Dishwasher PNC 535096
- Medium drying zone with door for Dual Rinse Rack Type Dishwasher PNC 535097
- Large drying zone with door for Dual Rinse Rack Type Dishwasher PNC 535098
- Corner drying zone for Dual Rinse Rack Type Dishwasher PNC 535099
- Medium hot air blower zone without door for dual rinse Rack Type dishwasher, 50Hz & 60Hz PNC 535141
- Emergency stop kit for Rack Type Dishwasher PNC 865162
- End limit switch for short roller conveyor PNC 865218
- Connection bracket for plain undershelf and grid undershelves (to be used if roller conveyor is connected directly to Rack Type dishwasher with splash hood) PNC 865235
- End limit switch for long roller conveyor (kit with two short rollers and end switch) PNC 865256
- Kit water softener for Rack Type dishwasher PNC 865284
- Kit water meter PNC 865286
- HACCP connection for Rack type dishwasher PNC 865490
- Kit water softener and reverse osmosis for Rack Type dishwasher PNC 865494

**Warewashing**  
**Dual rinse rack type dishwasher, 150 racks/hour, electric, 50Hz**

The company reserves the right to make modifications to the products without prior notice. All information correct at time of printing.

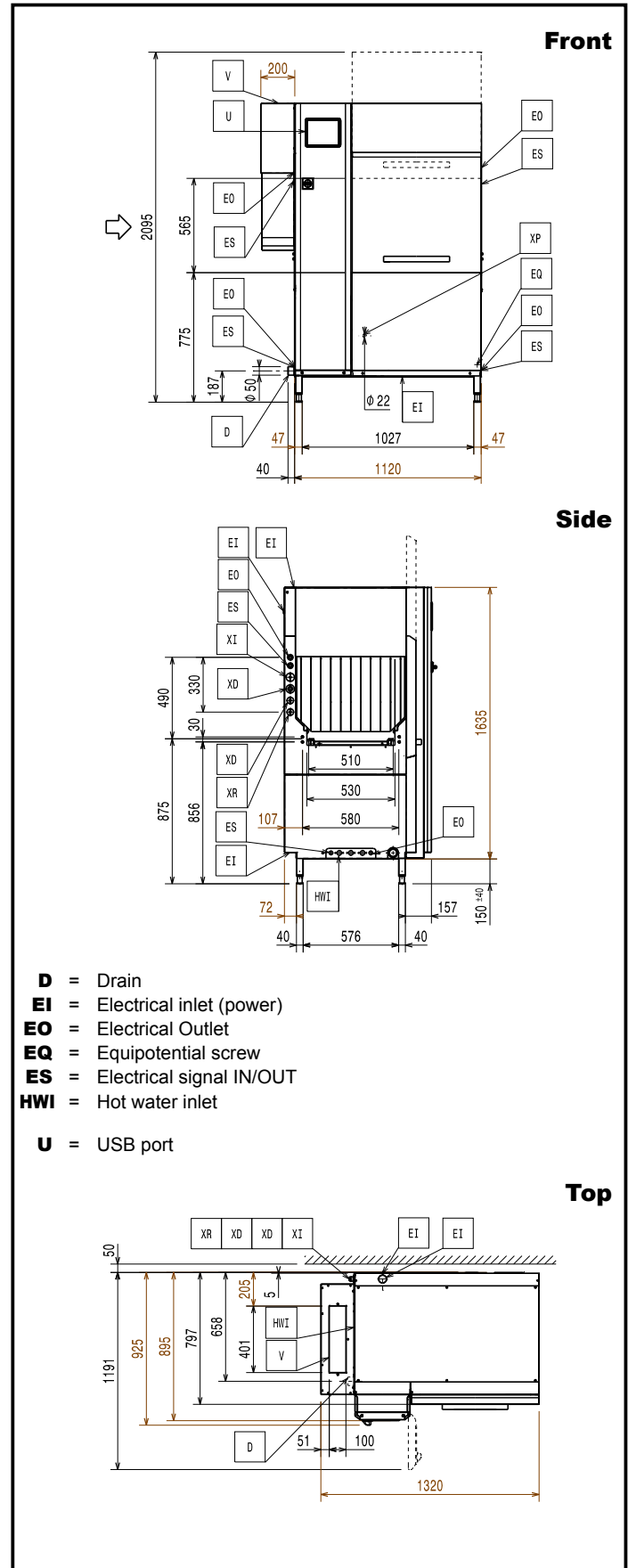
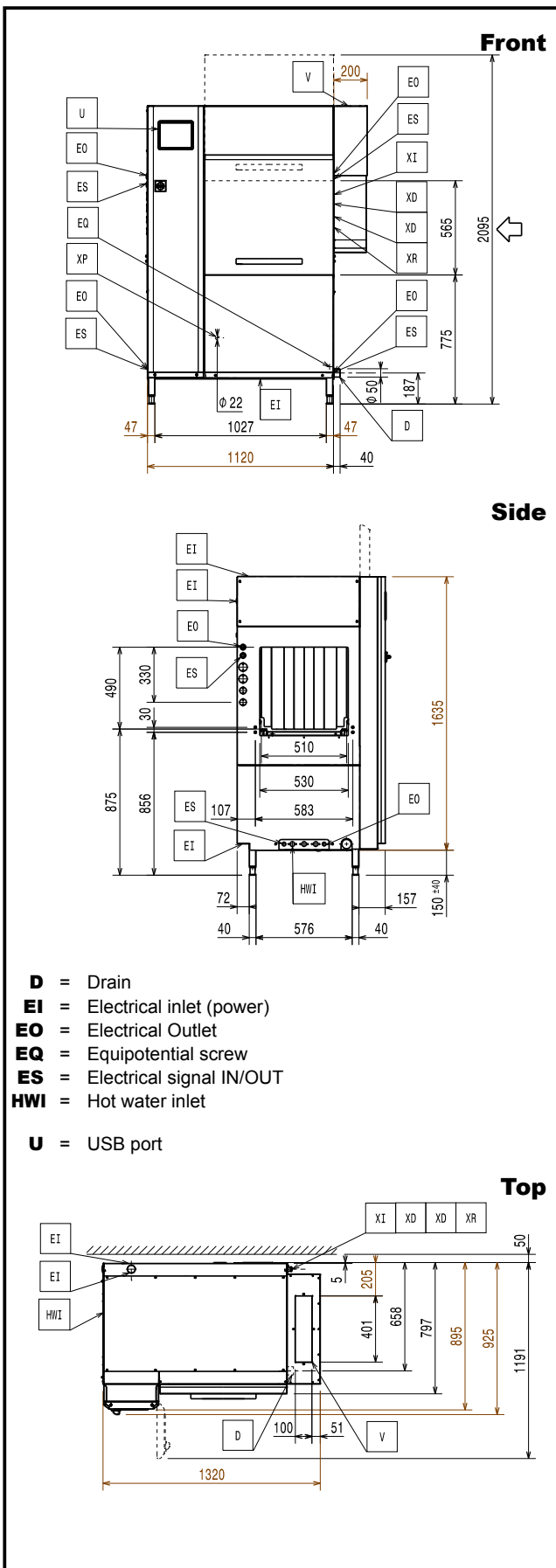

**Warewashing  
Dual rinse rack type dishwasher, 150 racks/hour, electric, 50Hz**

The company reserves the right to make modifications to the products without prior notice. All information correct at time of printing.

## Warewashing Dual rinse rack type dishwasher, 150 racks/hour, electric, 50Hz

### Electric

<b>Supply voltage:</b>	
<b>536035 (ZDR150EC5)</b>	380-415 V/3N ph/50 Hz
<b>Default Installed Power:</b>	22 kW
<b>Electrical power min:</b>	12 kW
When the machine is run at DIN 10512 compliant speed.	
<b>Boiler heating elements:</b>	10 kW
<b>Wash pump size:</b>	1.5kW
<b>Wash tank heating elements:</b>	10 kW

### Water:

<b>Inlet hot water line size:</b>	G 3/4"
<b>Drain line size:</b>	50mm
<b>Inlet water supply pressure:</b>	1.5-6 bar
<b>Inlet water supply temperature (wash and rinse):</b>	50 - 65°C
<b>Inlet water supply hardness:</b>	14 °fH / 8°dH
When below 7°fH/4°dH special detergent and rinse aid are needed.	
<b>Peak rate of drain flow:</b>	2.5 l/s
<b>Wash tank size:</b>	70 l
<b>Rinse water consumption:</b>	180 l/h

### Key Information:

<b>Productivity per hour (max. speed):</b>	150 racks/2700dishes
<b>Productivity per hour (medium speed):</b>	114 racks/2052 dishes
<b>Productivity per hour (DIN compliant speed):</b>	82 racks/1476 dishes
<b>Wash Temperature:</b>	55 - 65 °C
<b>Final rinse temperature:</b>	85 °C
<b>External dimensions, Width:</b>	1320 mm
<b>External dimensions, Depth:</b>	925 mm
For transportation purpose only, the depth can be reduced to either 895mm by removing the main switch button or 797mm by removing the control box and the door handle.	
<b>External dimensions, Height:</b>	1785 mm
<b>Height with door open:</b>	2095 mm
<b>Charging hole size (width):</b>	530 mm
<b>Charging hole size (height):</b>	490 mm
<b>Shipping height:</b>	1950 mm
<b>Shipping width:</b>	1010 mm
<b>Shipping depth:</b>	1260 mm
<b>Shipping volume:</b>	2.48 m <sup>3</sup>
Reference norm used to measure the noise: IEC60335-2-58 annex AA.	
<b>Table to table distance:</b>	1120 mm

### Air Emission:

<b>Air flow (top, exit):</b>	107 / 107 m <sup>3</sup> /h
<b>Air temperature (top, exit):</b>	45 °C
<b>Air humidity:</b>	100 % r.h.

The data is measured at exhaust points at 25°C and 60% r.h. ambient conditions, 18°C inlet water temperature and refer only to the machine.

<b>Latent heat:</b>	9100 W
<b>Sensible heat:</b>	3400 W

This model requires a ventilation hood. Please refer to the attached "Recommended Exhaust Hood Design".

### Sustainability

<b>Rinse water consumption at max speed:</b>	1.2 l/rack
<b>Noise level:</b>	<62 dBA

### Warewashing Dual rinse rack type dishwasher, 150 racks/hour, electric, 50Hz

The company reserves the right to make modifications to the products without prior notice. All information correct at time of printing.

**RECOMMENDED TABLE CONNECTION**

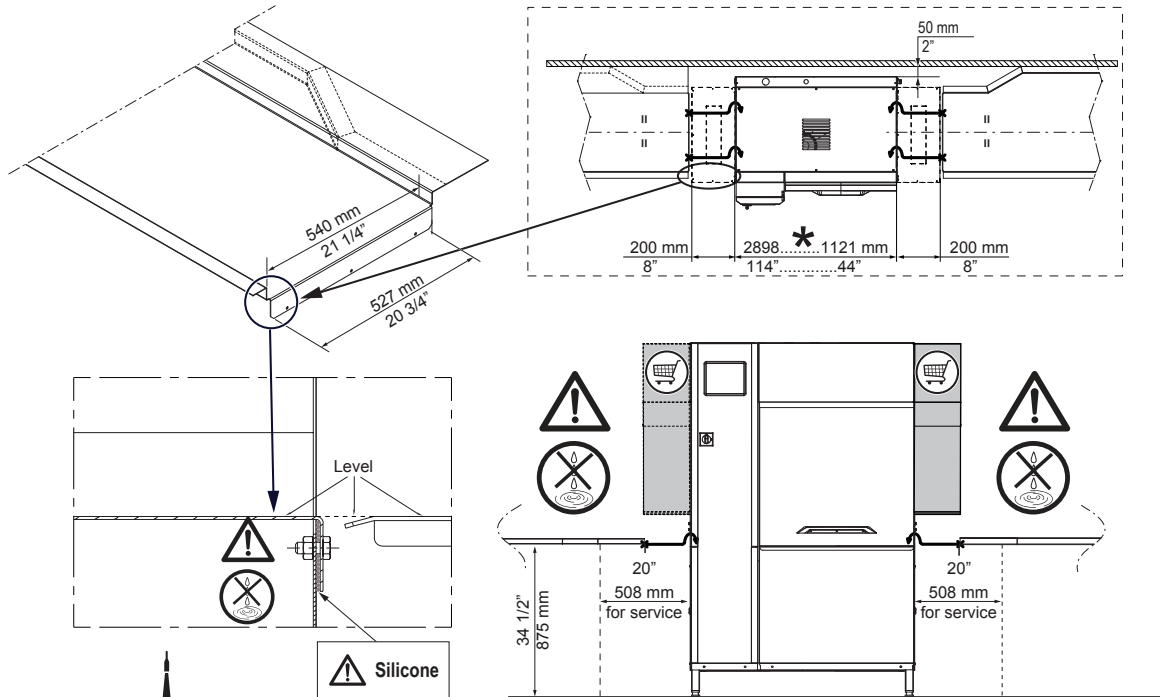

**SILICONE**

⚠ Apply silicone between the machine and the table and make sure that there are not any water leakages.  
Reference code 059611 for recommended silicone by Electrolux.

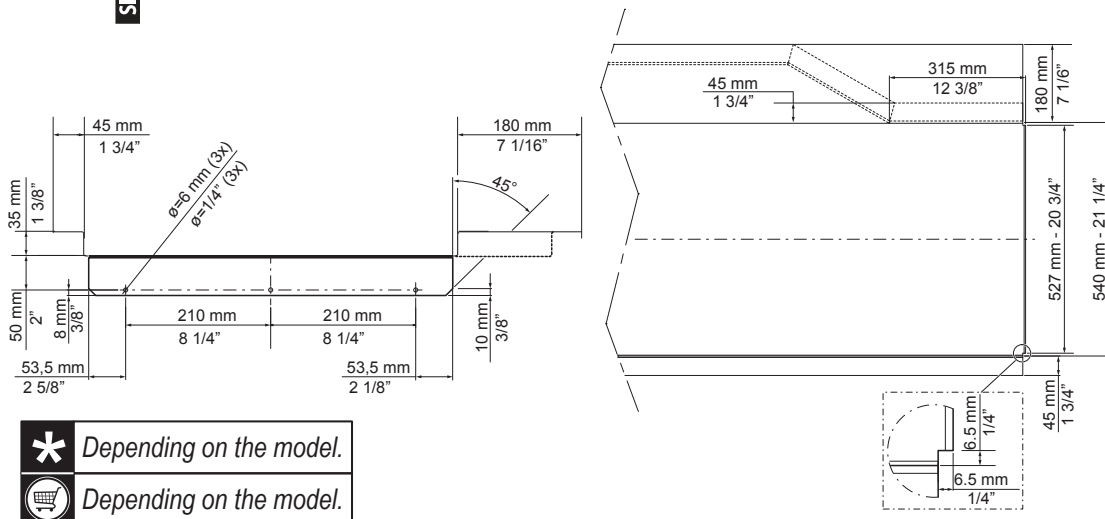

- \* Depending on the model.
- 🛒 Depending on the model.

All tables must be connected to the dishwashing units according to local regulations and industry standards which may differ from the recommendations herein suggested. Electrolux Professional is not liable for any failure in complying with local design standards.

DOC. NO. 59566QD00  
EDITION 01.2020